

Before beginning installation, please verify the following:

The vehicle hitch type and class is of adequate capacity to handle the weight of SegVator[®] and the Segway[®] PT(s) and the hitch is properly installed.

The vehicle has a standard 7-way round RV style electric plug installed with the aux. circuit connected. The aux. circuit is how SegVator[®] gets its power. The aux. circuit on the electric receptacle mounted to the vehicle has a prong at the one-o'clock position which is positive and the seven-o'clock position which is negative. A fuse/breaker of 40 amp capacity is necessary and may need to be added in the fuse block of the vehicle. Wiring must be 10 gauge or heavier if running additional wires to the vehicle plug. Consult your vehicle dealer to properly power SegVator[™].

SegVator[®] must be wired either directly from the fuse block or from the battery with an in-line 40 amp fuse and 10 gauge or heavier wire.

SegVator[®] also utilizes the running lights circuit to activate the power inverter via a power sensing relay. Vehicle engine and lights must be on to charge your Segway[®] PT(s). The running lights circuit must be wired into your vehicle electrical plug to use the power inverter. This is a safety feature to insure proper voltage and battery condition preventing potential battery drain.

VIEW

END OF SEGVATOR PLUG

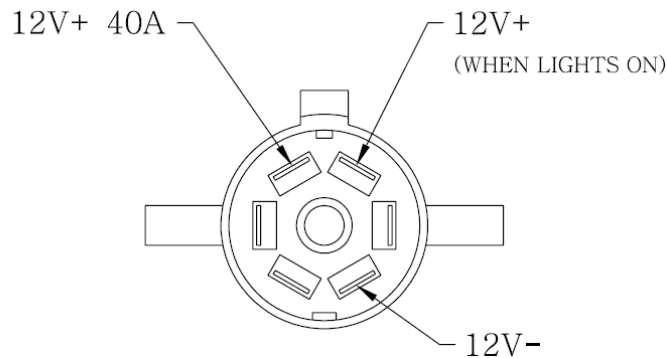

VEHICLE END SOCKET

